

LC-060 LOW PROFILE LOW VOLTAGE CONTROLLER

120-277 input voltage For lighting fixture applications Control for up to two loads

Low Voltage Controllers enable users to safely operate the high-voltage lighting found in hospital and nursing home rooms with their pillow speaker or bed communication side rail. They're tested and approved for use with all Nurse Call systems that use a switch with normally-open momentary dry contacts for auxiliaries.

- For use with fluorescent, LED, and other lamp types
- Can be used to operate high-voltage circuits such as lights, electric doors, and drapes
- Can be controlled from a pillow speaker, bed side rail, or wall switch with normally-open momentary dry contacts
- Controls two loads independently, or two loads sequentially
- Safe for use near medical equipment that is sensitive to electromagnetic noise

Input Voltage	120-277 VAC, 60 Hz 277 VAC, 5 A, General Use 277 VAC, 5 A, Ballast RMS current should not exceed 5 amps per load
Load Type	277 VAC, 5 A, General Use per Load 277 VAC, 5 A, Ballast per Load Maximum total device current: 10 A
Output Voltage	120-277 VAC, 60 Hz
Output Devices	<ul style="list-style-type: none"> Two 10 amp relays driven by low voltage microcontroller ESD protected.
Dimming Control	NA
Low Voltage Momentary Switch Requirements	Dry contacts, momentary, normally open, capable of switching 5 VDC @ 0.5 mA
Lamp	No restrictions
Switching Circuits Operation Voltage	5 VDC @ 0.5 mA
Power Supply Classification	Isolation from line voltage via a Class 2 transformer
Operating Temp. Range	32° to 167° F (0° to 75° C) Surrounding Air Ambient
External wires	White/Black: 16 AWG stranded All other wires: 18 AWG stranded
Mounting	Mounts next to a lighting ballast in lighting applications
Housing	.032" Galvanized Zinc-Plated Steel
Dimensions	6.75" with tabs (L) x 1.90" (W) x 1.20" (H)
Warranty	Three Years
Regulatory Listings and Compliance	UL/C-UL Listed to UL 508  Compliant with FCC Title 47 CFR 15 – Class B  RoHS compliant 

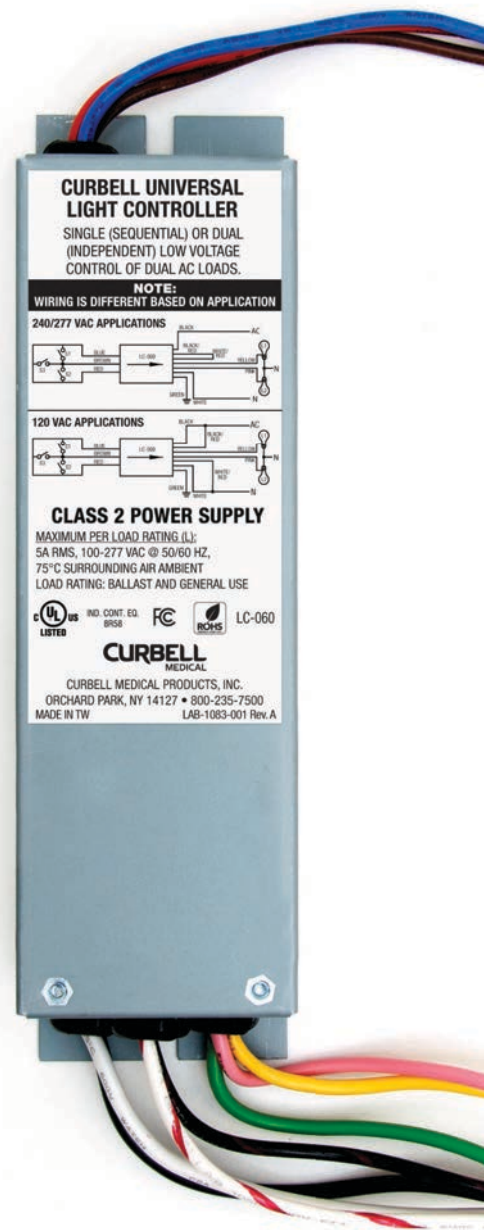

Product Design and Application

The LC-060 Low Voltage Controller is designed to mount inside a lighting fixture. All connections should be made within the lighting fixture and capped with wire nuts or equivalent. A qualified electrician should perform the installation.



This picture is for reference only and depicts a typical LC-060 installation with two individual lamp loads. Many alternate luminaires and installations may exist. Please consult with local NEC Codes and other applicable agency listing requirements for specific installations requirements.

Wiring

The three wires on the low voltage side of the unit are designated as red, blue, and brown. When wiring as a single momentary switch, sequential controller, you must connect the red and blue wires together to one side of the switch. The brown wire is the other side of the switch. This wiring can be connected to a receptacle, or directly to a pillow speaker if it is hard wired to the nurse call system (Figure 1). When wiring as a two switch combination control, the brown wire is common for the two switches. Blue is S1 and red is S2 (Figure 2).

On the other side of the control housing is the high voltage side, which has three groups of wires.

One group is the AC voltage in. It consists of a black wire (hot), and a white wire (neutral).

The second group of wires is the AC voltage out to the load (lights). It consists of a yellow wire (hot, load 1), a pink wire (hot, load 2), and a green wire (earth ground). These connections go directly to the room lights, or other devices being controlled, and earth ground.

The third group of wires is for input voltage designation (a black wire with red stripe and a white wire with red stripe).

For 120 volt applications: the black wire with red stripe gets wired to the black (hot) wire and the white wire with red stripe gets wired to the white (neutral) wire.

For 277 volt applications: the black wire with red stripe and the white wire with red stripe get wired together and capped off.

Figure 1: For one SPST momentary switch, sequential

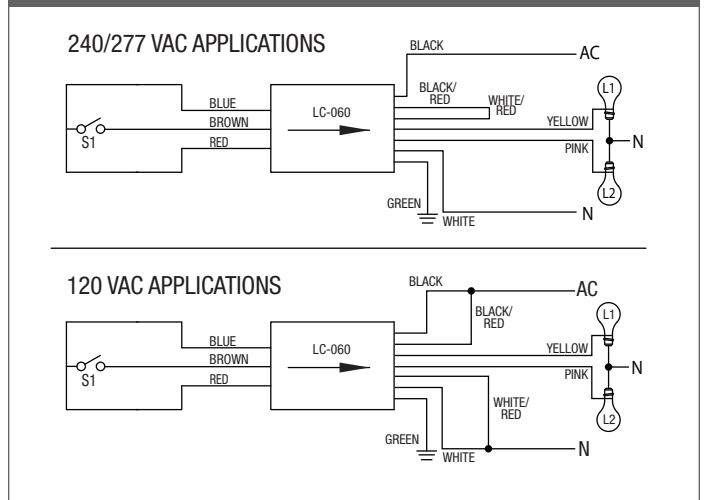
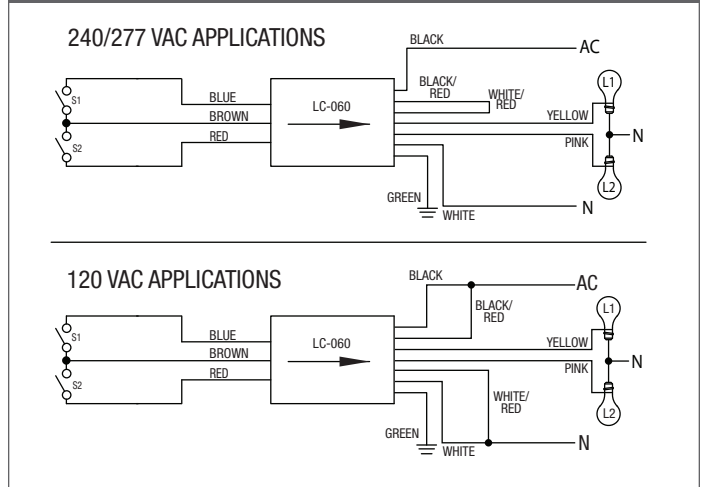

Figure 2: For one or two individually controlled SPST momentary switches, combination



These illustrations are not intended for installation purposes. For complete instructions, refer to the Directions For Use provided with the unit.

Momentary Switch States - Sequential Controller

Switches will reset to off position if power is interrupted for more than one second.

	Load 1	Load 2
After power up	Off	Off
1st Switch	On	Off
2nd Switch	Off	On
3rd Switch	On	On
4th Switch	Off	Off

These illustrations are not intended for installation purposes. For complete instructions, refer to the Directions For Use provided with the unit.